

Understanding centrifugal compressor performance

In a connected process system, expensive changes to the compressor and driver can be avoided with system debottlenecking modifications. The authors give examples of cost effective ways of increasing compressor suction pressure

Scott W Golden Scott A Fulton Daryl W Hanson

Process Consulting Services Inc

Wet gas compressor capacity limits feed rate or unit conversion in many FCC and delayed coker units. Understanding compressor performance and its interaction with the connected process systems is critical when revamping FCC and delayed coker units. Unnecessary changes are frequently made to the compressor and driver. Alternatively, lower cost process system modifications can be used to debottleneck a compressor limit. Figure 1 is a block diagram of a compressor and the connected process system components.

The connected process system and compressor performance must be thoroughly evaluated as a single system to determine the most cost effective way to increase compressor capacity. Conventional process design approaches use several equipment disciplines to evaluate piping, heat exchange, and distillation systems independently. Thus, the opportunity to debottleneck the compressor with lower cost process system changes may go unnoticed.

Reducing system pressure drop to increase suction pressure or decrease discharge pressure allows more gas to be compressed through the compressor without modifications, as outlined below.

Process equipment pressure drop:

- Main column internals
- Piping/nozzles
- Control valves
- Fin-fans
- Shell and tube exchangers
- Flow metering

However, the impact of suction and discharge system changes on compressor capacity is not the same. Suction pressure changes have a much stronger influence on compressor capacity due to their effect on overhead receiver condensation, gas density, and compressor head.

Process system operating pressure and system pressure drop strongly influence wet gas compressor capacity. Compressor discharge and suction pres-

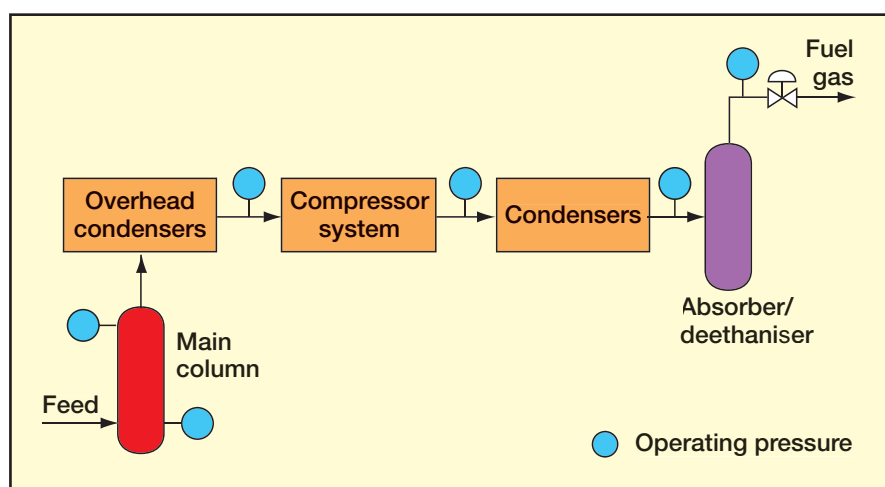

Figure 1 Compressor and connected process system

sure are variables and should be manipulated whenever possible to raise compressor capacity. Increasing compressor suction pressure and reducing discharge pressure will increase compressor capacity. Finding cost effective solutions always starts with field measurements of the current operation to identify high pressure drop components. Distillation column internals, process piping, heat exchangers, control valves and flow metering in the connected process system must be modelled together with the compressor to quantify compressor capacity increases resulting from equipment modifications.

In an FCCU, feed rate, reactor/regenerator differential pressure and system pressure drop set compressor suction pressure. In a coker, coke drum constraints and the system pressure drop set suction pressure. Discharge pressure is controlled by the gas plant operating pressure and system pressure drop. Practical changes to consider include process flow scheme, tower internals, heat exchangers, piping/nozzles, control valves, and orifice plate modifications.

These components all generate pressure drop. Process flow scheme changes

may include adding a pumaround to the main column or bypassing absorber bottoms liquid around the high pressure condenser to reduce pressure drop.

System pressure drop between the main column inlet nozzle and the compressor inlet will vary from a low of 5psi to over 25psi. High pressure drop components need to be identified and cost-effective and reliable changes made. In some instances, replacing main column trayed internals with structured packing will be the low-cost solution. At other times, condenser system pressure drop will control compressor suction pressure. Therefore, piping, fin-fan, shell and tube exchanger, control valve, or flow metering modifications will need to be considered.

Absorber operating pressure and system pressure drop set the compressor discharge pressure (Figure 1). Lower discharge pressure reduces compressor head and driver power, which increases compressor capacity. Discharge pressure should be minimised without reducing gas plant performance. Absorber pressure controls C_3 recovery, assuming other process variables have been optimised.

In a few instances, reducing absorber operating pressure will not materially

change C_3 recovery. In most cases, however, propylene recovery drops as pressure is reduced and it is not a cost effective way to increase compressor capacity. If the existing compressor discharge system has high pressure drop, then equipment changes may be an effective means to debottleneck the compressor. Typically, compressor discharge pressure will need to be reduced by at least 20psi to have a meaningful effect on compressor capacity and driver power.

Compressor fundamentals

Most FCC and delayed coker wet gas compressors have an inter-cooler system that improves compressor efficiency and reduces the gas temperature rise through the stages of compression. Inter-cooled compressors will have a low-stage curve defining performance upstream of the inter-cooler and a high-stage curve for the downstream portion. In reality, the low and high-stages will have three to four actual wheels, each with their own individual performance curves.

These low and high-stage performance curves are a composite of the individual stage curves. Usually these low and high-stage curves are sufficient to evaluate compressor performance and the connected process system's influence on compressor capacity.

Centrifugal compressors have performance curves similar to pumps. The major difference is that a compressor moves gas which is compressible, while the pump moves liquid that is not compressible. The compressor curve flow term is always based on inlet conditions. Consequently, inlet gas density influences volumetric flow.

Flow is shown on the X-axis and head on the Y-axis. For a fixed speed, the curve shows that for a known inlet flow rate a fixed head is developed. Centrifugal compressor inlet flow rate increases as the head decreases. Gas plant operating pressure, connected system pressure drop, and gas composition sets the developed head. Increasing suction pressure, decreasing gas plant operating pressure and/or decreasing process system pressure drop will increase inlet flow rate as long as the compressor is not operating at choke flow.

A compressor curve starts at the surge point and ends at stonewall, or choke flow. The surge point is the head at which inlet flow is at its minimum. At this point, the compressor suffers from flow reversal, which is a very unstable operation that is accompanied by vibration and possible damage. On the other end of the curve is the choke (or stonewall) point. At the choke

point, the inlet flow through the compressor cannot increase no matter what operating changes are made. Therefore, the range of compressor performance is defined between these two flow-head limitations.

Typically, the curve is flat near the surge point and becomes steeper as flow is increased. Hence, small head changes near the surge point cause a large increase in compressor capacity. As compressor operation moves toward stonewall, decreasing head has less influence on inlet flow rate because the curve slope increases. As the stonewall point is approached, changes in head will have negligible effect on inlet flow rate.

Compressor inlet flow

The performance curve flow rate is based on suction conditions and expressed as inlet cubic feet per minute (ICFM). It is not standard gas flow metering units. Wet gas is a compressible fluid, therefore changes in compressor suction conditions that increase gas density will reduce wet gas volumetric flow rate and free up compressor capacity.

Gas density is a function of temperature, pressure, and gas molecular weight. Gas density is calculated from the ideal gas law shown in Equation 1. For a fixed mass flow rate and gas composition, temperature has a small effect on gas density because the temperature term is very large. Conversely, increasing compressor suction pressure will significantly increase gas density and reduce the gas volume.

The lower the suction pressure the larger the effect of pressure changes on compressor capacity. For example, increasing pressure from 18.7psia to 20.7psia decreases the inlet gas flow rate by 10.6 per cent for the same mass flow rate. When the suction pressure is 44.7psia the same 2psi change reduces gas volume by only 4 per cent.

$$\text{Gas density} = P (MW)/RT \quad (1)$$

where

- P = gas pressure (absolute)
- T = gas temperature (absolute)
- MW = gas molecular weight
- R = gas constant.

Increasing gas molecular weight (MW) will also increase gas density and reduce volume for a fixed mass flow rate. Reactor and coke drum effluent composition controls gas molecular weight. FCC dry gas typically has a molecular weight in the range of 21–23. Typical propylene/propane mixtures have a molecular weight of 43.5.

As the FCC reactor reduces the dry gas yield and increases heavier C_3 and C_4 s yield, the wet gas molecular weight

“For a fixed mass flow rate and gas composition, temperature has a small effect on gas density because the temperature term is very large. Conversely, increasing compressor suction pressure will significantly increase gas density and reduce the gas volume”

and wet gas density increase, thus reducing inlet volume. A 5 per cent increase in gas molecular weight decreases inlet volume flow rate by 5 per cent for a fixed temperature and pressure.

Compressor head

Centrifugal compressors do not develop a constant differential pressure; they develop a constant differential polytropic head at a given inlet flow rate. Often, the compressor curves provided by the E&C company or the compressor vendor will report the performance curve as differential pressure versus inlet flow rate.

These differential pressure curves represent one set of inlet operating conditions only. They are not sufficient to evaluate the compressor and connected system performance. Understanding the components of this head term is essential when considering the influence of the process operating pressure and the system pressure drop's effect on compressor capacity.

Equation 2 shows the polytropic head term.

$$\text{Head} = \frac{1,545 Z_{AVG} T_1}{MW \left(\frac{n}{n-1} \right)} \left[\left(\frac{P_2}{P_1} \right)^{\left(\frac{n-1}{n} \right)} - 1 \right]$$

where

- MW = Molecular weight
- Z_{avg} = Average compressibility
- T_1 = Suction temperature, °R
- n = Compression coefficient
- P_1 = Suction pressure, psia
- P_2 = Discharge pressure, psia

Reducing polytropic head will increase compressor capacity by moving the operating point to the right except at stonewall. The slope of the curve will determine the magnitude of the inlet flow rate increase resulting from a given polytropic head reduction. Process changes that move the

operating point to the right include higher gas molecular weight, raising suction pressure, or lowering discharge pressure. Gas temperature changes have little influence on head.

Compressor molecular weight is set by the coke drum or FCC reactor gas composition. Suction pressure changes of 5psi or higher can also influence gas composition and molecular weight through the impact of condensation.

Compressor suction and discharge pressure both influence the polytropic head. Compressor discharge pressure is set by the gas plant operating pressure and the pressure drop from the compressor discharge to the absorber pressure control valve.

For instance, compressor discharge and suction pressures of 220psig and 10psig, respectively, are common. Therefore, the pressure ratio term is 234.7psia:24.7psia, or 9.5. Reducing head requires a decrease in the pressure ratio term. This simplified evaluation ignores the influence of the inter-stage system.

Understanding how discharge and suction pressure influence the polytropic head term and compressor capacity is the key to evaluating potential connected process system modifications.

Figure 2 represents the influence of a 1500ft head reduction on compressor inlet flow rate for one compressor. Increasing suction pressure P_1 or decreasing discharge pressure P_2 will reduce head. Quantifying the suction and discharge pressure changes that result in the same polytropic head reduction is useful. Either increasing suction or decreasing discharge pressure can be used to reduce polytropic by 1500ft and increase the compressor inlet flow capacity by 6 per cent.

Suction pressure changes have a much larger influence on compressor capacity than discharge pressure changes. Raising suction pressure by 2.0psi decreases the head by 1500ft as a result of reducing the pressure ratio term from 9.5 (234.7psia:24.7psia) to

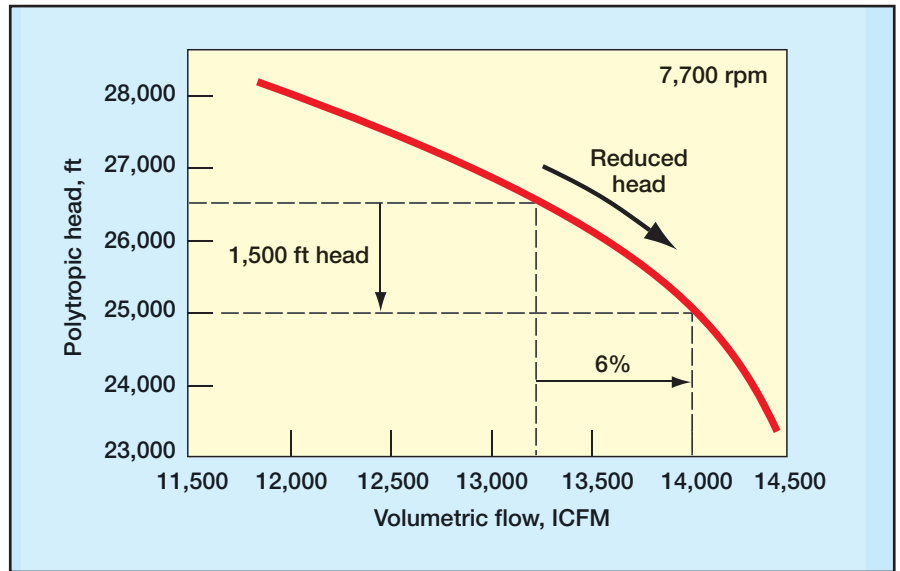

Figure 2 Compressor performance curve: polytropic head reduction

8.8 (234.7psia:26.7psia). The compressor discharge pressure would have to be lowered from 220psig to 202psig ($P_2/P_1=216.7 \text{ psia}/24.7 \text{ psia}=8.8$) to produce the same head reduction. Reducing gas plant operating pressure reduces propylene recovery and an 18psi operating pressure reduction is generally not feasible. On the other hand, it may be possible to reduce system pressure drop by 18psi. Suction pressure changes of 2psi, however, are practical on many units.

Driver power

Compressor driver power requirements can also limit the compressor maximum flow rate. When the drivers are limited, the turbine steam rate and speed or the motor amps are at maximum. Compressor driver power consumption is a function of the mass flow, compressor polytropic head, compressor efficiency, and gear efficiency. Compressor shaft horsepower (SHP) is shown in Equation 3:

$$\text{Compressor SHP} = \frac{(m)H_p}{(n_p)33000} \cdot 1.02 \quad (3)$$

where

H_p = Polytropic head

SHP = Shaft horsepower
 m = Mass flow rate of gas
 n_p = Polytropic efficiency
 1.02 = 2% gear losses

Reducing polytropic head lowers the compressor shaft horsepower.

Unit operations

Wet gas compressors increase the system operating pressure so that C_3-C_{12} hydrocarbon components can be recovered as liquid product. Compressor system operating suction and discharge pressure will vary depending on reactor/regenerator, coke drum, gas plant, compressor and/or upstream equipment design and operation.

The compressor takes suction from the main column overhead receiver or downstream knockout drum, which operates at 1.5–30psig and discharges to a gas plant absorber/deethaniser system operating at 160–240psig.

Main column overhead receiver temperature and pressure determine the amount of wet gas production for a fixed reactor effluent or coke drum composition. Increasing compressor inlet pressure and/or decreasing temperature reduces the wet gas mass flow

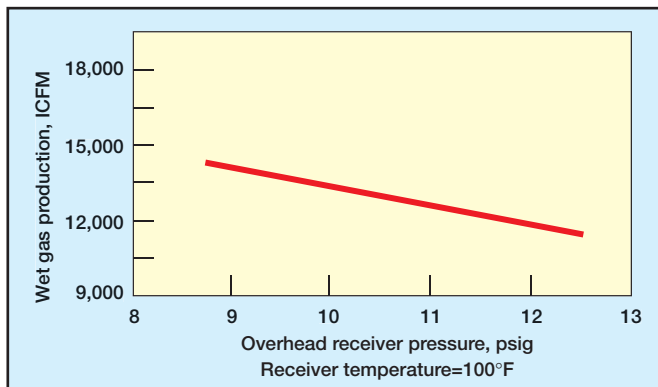

Figure 3 Suction pressure vs wet gas production

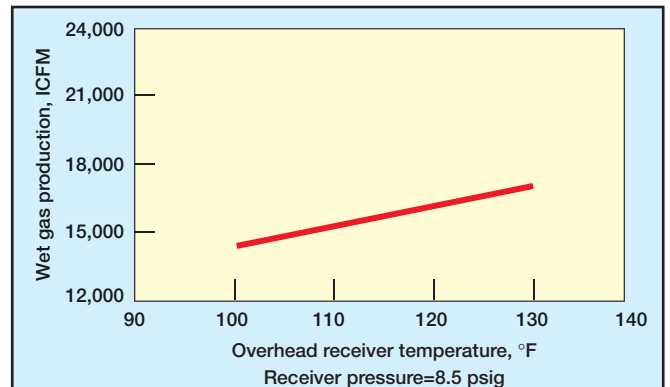

Figure 4 Suction temperature vs wet gas production

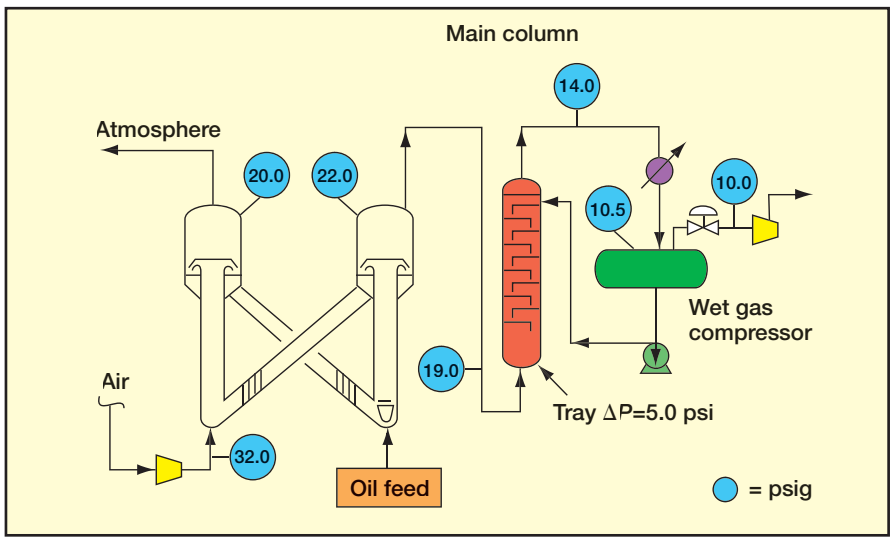

Figure 5 Main column with trays pressure profile

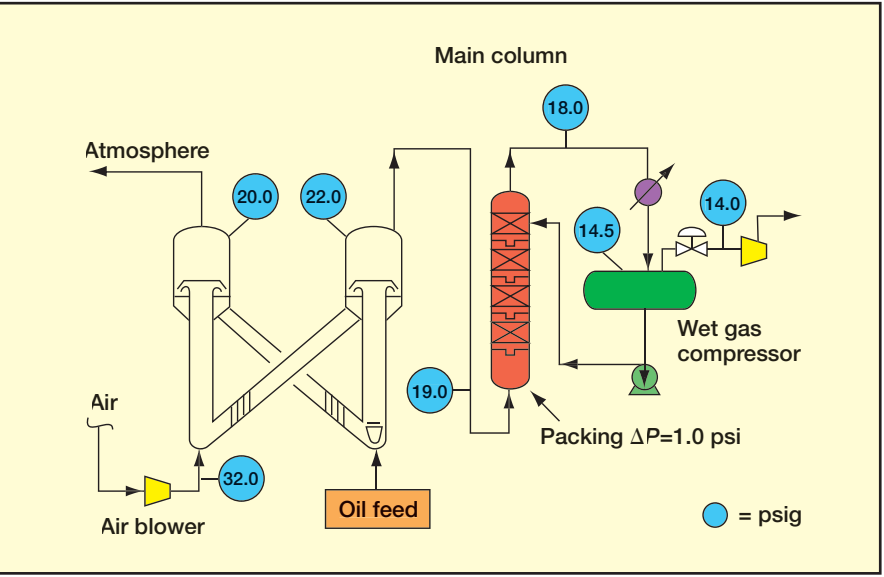

Figure 6 Main column with packing pressure profile

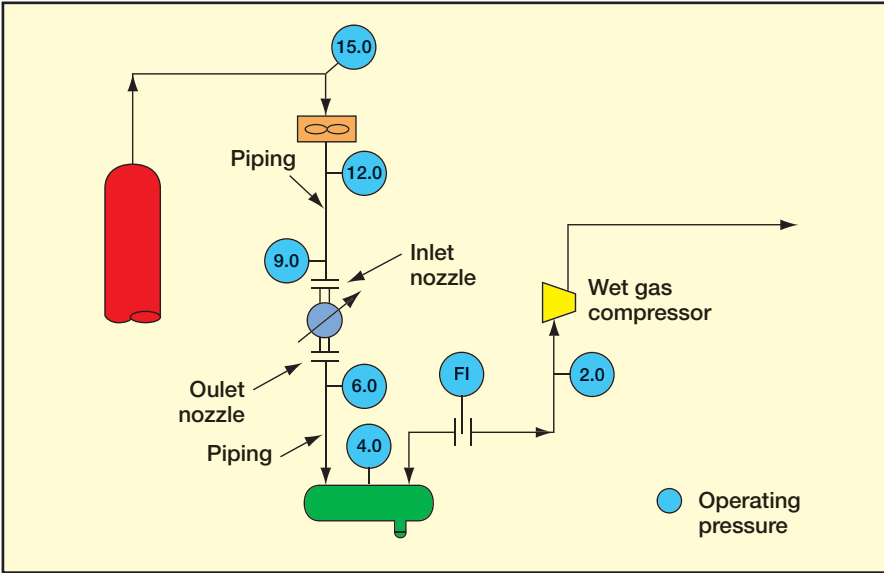

Figure 7 FCC measured pressure drop

rate by changing the amount of condensation that occurs. Compressor suction pressures and temperatures vary from 1.5 to 30psig and 80°F to 135°F, respectively.

Main fractionator pressure and temperature can be optimised through equipment changes. Figures 3 and 4 show the effect of pressure and temperature on wet gas rate for one unit. A low-capital revamp may involve replacing the four-tube row fin-fan bundles with six-row bundles. The six-tube row bundles will have less than the half the pressure loss of the four-tube rows and add surface area that can lower receiver temperature. In one instance, this raised compressor capacity by over 20 per cent by increasing receiver pressure by 2psi and reducing temperature by 10°F.

Increasing suction pressure

Three revamp examples highlight the relationship between the connected process system pressure drop, compressor performance curves, and wet gas compressor capacity. These case histories demonstrate cost effective ways to increasing compressor suction pressure by utilising structured packing, reduced piping pressure drop and reduced fin-fan pressure drop.

**Case history 1
Structured packing**

A 50000bpd unit was revamped to increase capacity to 65000bpd. Wet gas compressor capacity was one of the major unit limits. Revamping the compressor, installing a new parallel compressor, or reducing connected system pressure drop were all evaluated and cost estimates generated for each option. Compressor performance curves, driver horsepower and connected system pressure drop were all thoroughly studied.

Compressor modification required changes to the compressor internals, motor replacement, new motor control centre gear, and substation modifications. A new parallel compressor was very expensive and increased operating complexity. Reducing system pressure drop was the least-cost option.

Compressor suction pressure drop includes the main column, condenser system, and piping. Condenser and overhead system pressure drop were only 2.5psi. Main column pressure drop was 5psi, which represented over 60 per cent of the suction system pressure loss.

The unit pressure profile is shown in Figure 5. The main column overhead receiver operated at 10psi. The revamp replaced the trays with structured packing (Figure 6). This reduced column pressure drop to 1.0psi. Compressor inlet pressure was increased from 10 to

14psi. This increased condensation, increased gas density, decreased compressor polytropic head, and decreased the inlet volume to the compressor.

All this increased compressor mass flow capacity by over 30 per cent without changes to the compressor or the driver.

Case history 2

Reduced piping pressure drop

A 40000bpd unit was revamped to add a heavy naphtha draw and increase unit capacity by 20 per cent. Heavy naphtha contains a large portion of the gasoline sulphur, and the gas plant liquid handling bottlenecks limited unit conversion. Wet gas compressor capacity was one of the revamp limits.

A consequence of the heavy naphtha draw is that wet gas production increases as overhead gasoline rate decreases. Prior to the revamp, the compressor was operating at maximum capacity. Unlike Case history 1, where the main column had high pressure drop, here the column pressure drop was only 2.5psi. Piping and condenser system represented almost 85 per cent of the total system pressure loss. This emphasises that accurate field measured pressure drop must be done as part of preparing for any revamp.

The overhead system pressure profile shown in Figure 7 had a measured pressure drop of 13psi. Pressure drop from the fin-fan outlet to the compressor was 10psi. The revamp replaced the piping downstream of the fin-fans, shell and tube exchanger shell, piping to the overhead receiver, and orifice plate. Compressor inlet pressure was increased from 2psi to 7.5psi (Figure 8).

This increased condensation, increased gas density, decreased compressor polytropic head, and decreased the inlet volume to the compressor. This raised compressor mass flow capacity by over 30 per cent.

Case history 3

Reduced fin-fan pressure drop

A delayed coker unit revamp objective was to increase capacity by 25 per cent. The unit was operating at the maximum compressor capacity. If compressor suction pressure and temperature were maintained at current conditions, increasing the gas flow rate by 25 per cent would require major compressor and driver modifications at a cost of more than \$2 million. Hence, more cost effective process system changes were evaluated.

The study began with a comprehensive field test run to gather all the necessary data to calibrate process and equipment models. This was the critical first-step in establishing all significant

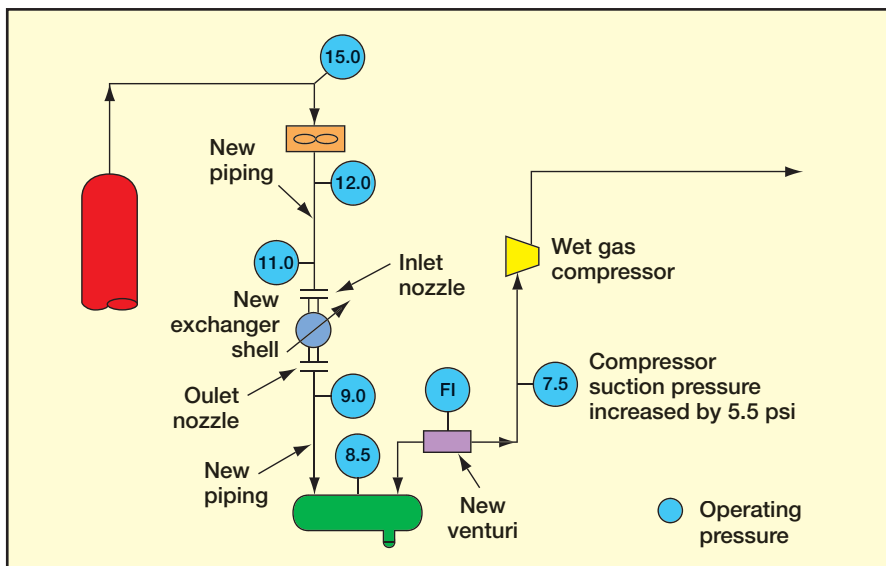

Figure 8 FCC revamp pressure drop

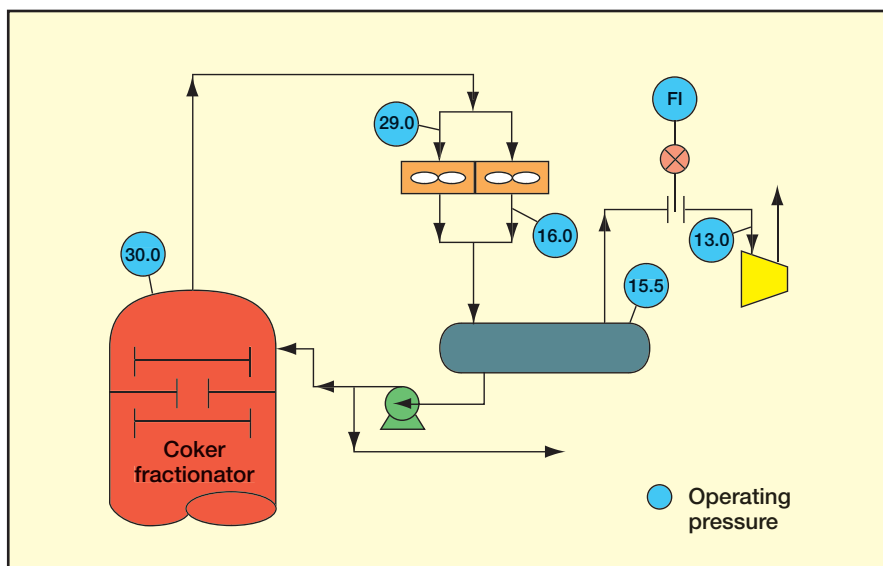

Figure 9 Delayed coker measured pressure drop

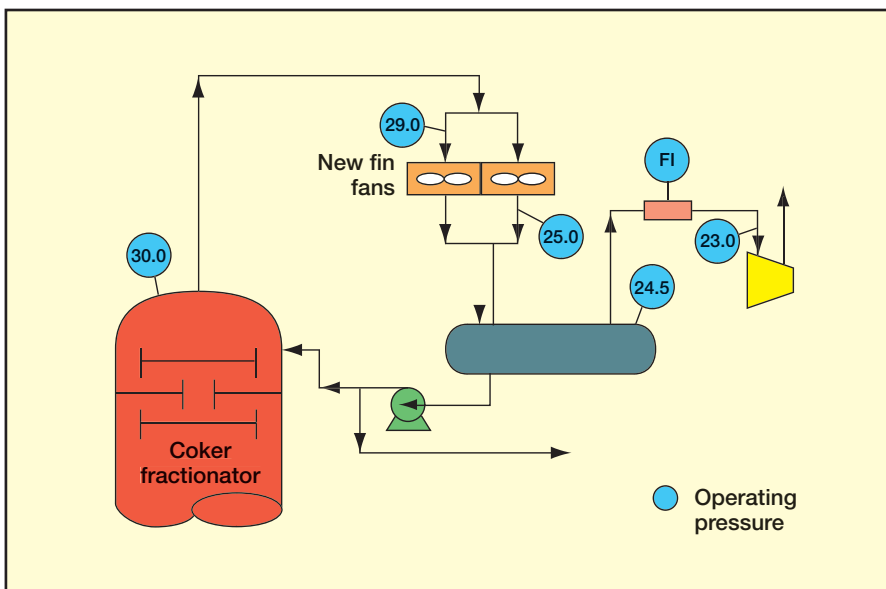

Figure 10 Delayed coker revamp pressure drop

unit bottlenecks. As part of the test run, the column and overhead system pressure profile was measured with two digital pressure gauges.

Pressure readings between any two points were taken simultaneously with gauges accurate to within ± 0.03 psi. The unit pressure profile is shown in Figure 9. Measured overhead system pressure drop was 16psi with 13psi measured across the fin-fans alone.

The pressure drop from the overhead receiver to the compressor was 2.5psi with more than 50 per cent across of the orifice meter. Hence, measured pressure profiles clearly pinpointed the high pressure drop components.

As noted, modifying the compressor would be very costly. Reducing fin-fan and orifice plate pressure loss would be a more cost effective alternative. Compressor inlet pressure could be increased from 13psi to 23psi (Figure 10) with its resultant benefits. Process system changes from the main column overhead to the compressor would include a new fin-fan bay in parallel to the existing bays, new fin-fan bundles with additional tube row design to lower pressure drop and increase surface area, and larger fan motors to raise the air rate.

Thus, overhead receiver temperature could be maintained at pre-ramp conditions with a 10psi increase in compressor suction pressure. In addition, compressor discharge system condenser pressure loss (Figure 1) would be very high at increased gas flow. Discharge system condenser modifications would permit lower compressor pressure. These changes would debottleneck the wet gas compressor limit without changes to the compressor or auxiliaries.

Increased condensation, increased gas density, decreased compressor polytropic head, and decreased inlet volume to the compressor would be the outcome. This would permit a 25 per cent increase in feed rate without any compressor modifications. The cost would be a fraction of a new compressor.

distillation and holds a BS degree in chemical engineering from the University of Maine.

Daryl W Hanson is a chemical engineer with Process Consulting Services. His responsibilities include process and equipment design and field troubleshooting. He specialises in refinery distillation, from process simulation to field inspection. He has written more than 20 technical papers on revamping, troubleshooting, and distillation and holds a BS degree in chemical engineering from Texas A&M University.

Scott A Fulton is a chemical engineer with Process Consulting Services. He has worked on 10 FCC unit revamps in his current position, where he is responsible for process flow sheet modelling, conceptual design, and detail equipment modelling and design. He has written papers on revamping and holds a BS degree in chemical engineering from Texas A&M University.

You can air your views on this subject on our Readers Forum: www.eptq.com

Scott W Golden is a chemical engineer with Process Consulting Services, Houston, Texas, USA. His previous experience includes refinery process engineering and distillation troubleshooting and design. He has written more than 80 technical papers on revamping, troubleshooting, and