

FCC gas concentration unit stripper revamp

Unit charge rate and reactor conversion were increased by the elimination of stripper column flooding. Chemical-grade propylene specifications were met and C₂ excursions in mixed C₂/C₃ streams were eliminated

Dave Langdon *Total Lindsey Oil Refinery*

Scott Golden and Edward Hartman *Process Consulting Services Inc*

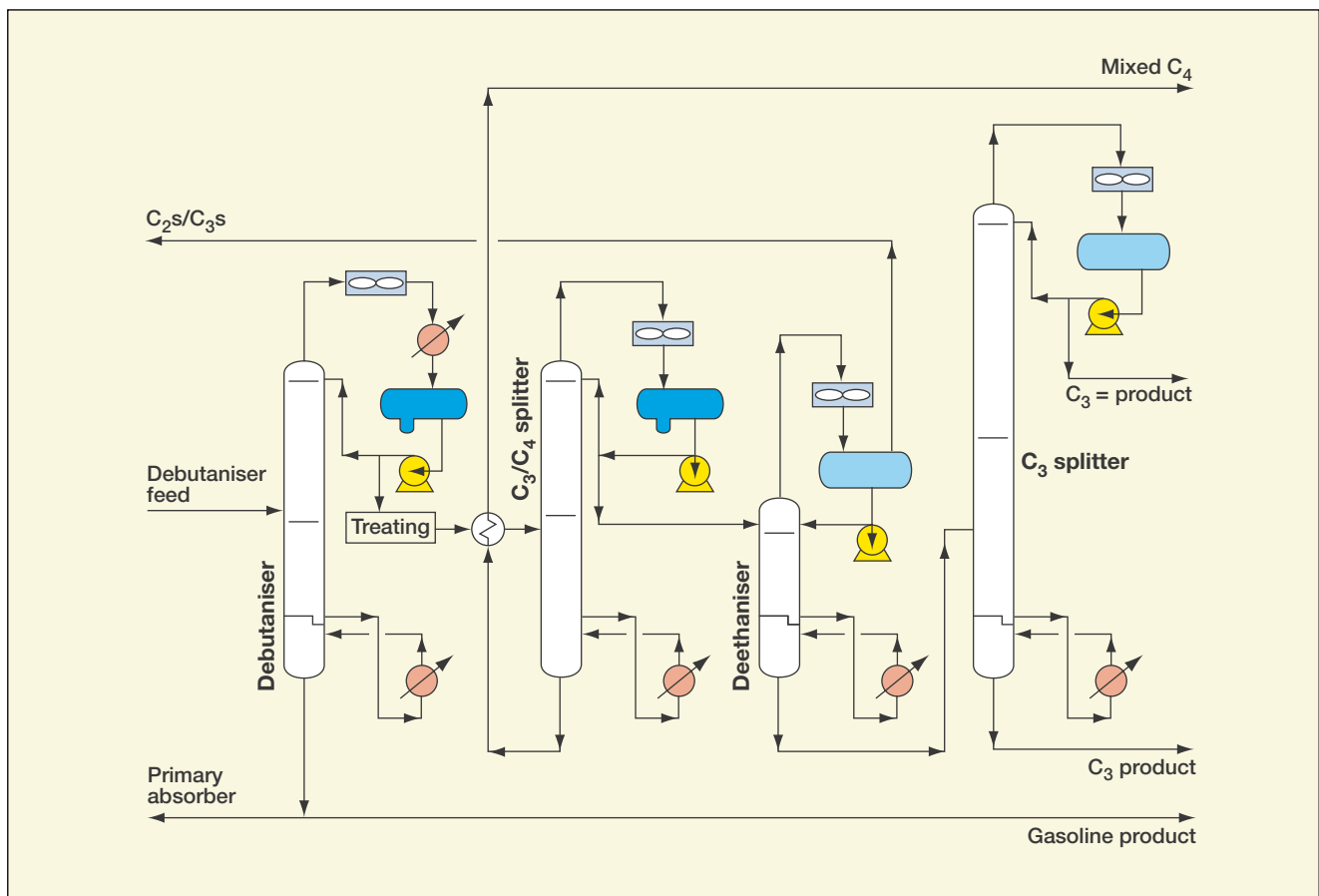

Figure 1 Generic process flow scheme of GCU fractionation system (note: the Lindsey refinery GCU operates with two C₃ splitters)

The FCC gas concentration unit (GCU) stripper column at the Total Lindsey Oil Refinery (LOR) was revamped in 2005 to eliminate flooding, consistently maintain C₂s in GCU mixed C₃s at 5000 ppmwt or less (ie, <5000 ppmwt C₂s in C₃ mixture) and maximise C₃ recovery (Figure 1). Flooding in the stripper column limited the FCC unit's (FCCU) charge rate and reactor conversion prior to the revamp, requiring a bypass from the main column's overhead receiver to the bottom of the stripper to manage flooding. C₂s excursions in the GCU mixed C₃s exceeding 20 000 ppmwt were also noted. Since LOR produces chemical-grade propylene

(C₃=) requiring C₃= that exceeds 95% purity with total C₂s and ethylene specifications of 400 and 50 ppmwt respectively, these 20 000+ ppmwt C₂ excursions were unacceptable, as they overloaded the C₂ stripping capacity of the two downstream propane/propylene (PP) splitting units. FCCU conversion had to be reduced to the stripper column's hydraulic limit to meet the C₃= product specifications. Following the revamp, stripper column flooding was eliminated, total C₂s in the GCU mixed C₃s were reduced to an average of 3000 ppmwt, and the FCCU's reactor charge rate and conversion has increased to record levels. The stripper column's feed rate is 33% higher than before

the revamp, with no further flooding, and is no longer the FCCU's constraint.

Pre-revamp operation

Prior to the revamp, the stripper column limited the FCCU's charge and conversion for several years. During the previous turnaround, the column internals were revamped to increase capacity, but the stripper did not meet its design objectives. Following the 2000 revamp, the reactor's outlet temperature (ROT) had to be reduced 15°F (8°C) to lower the gasoline and LPG yield. Additionally, a wild naphtha product bypass line was installed from the main column's overhead receiver to the base of the stripper column to reduce the

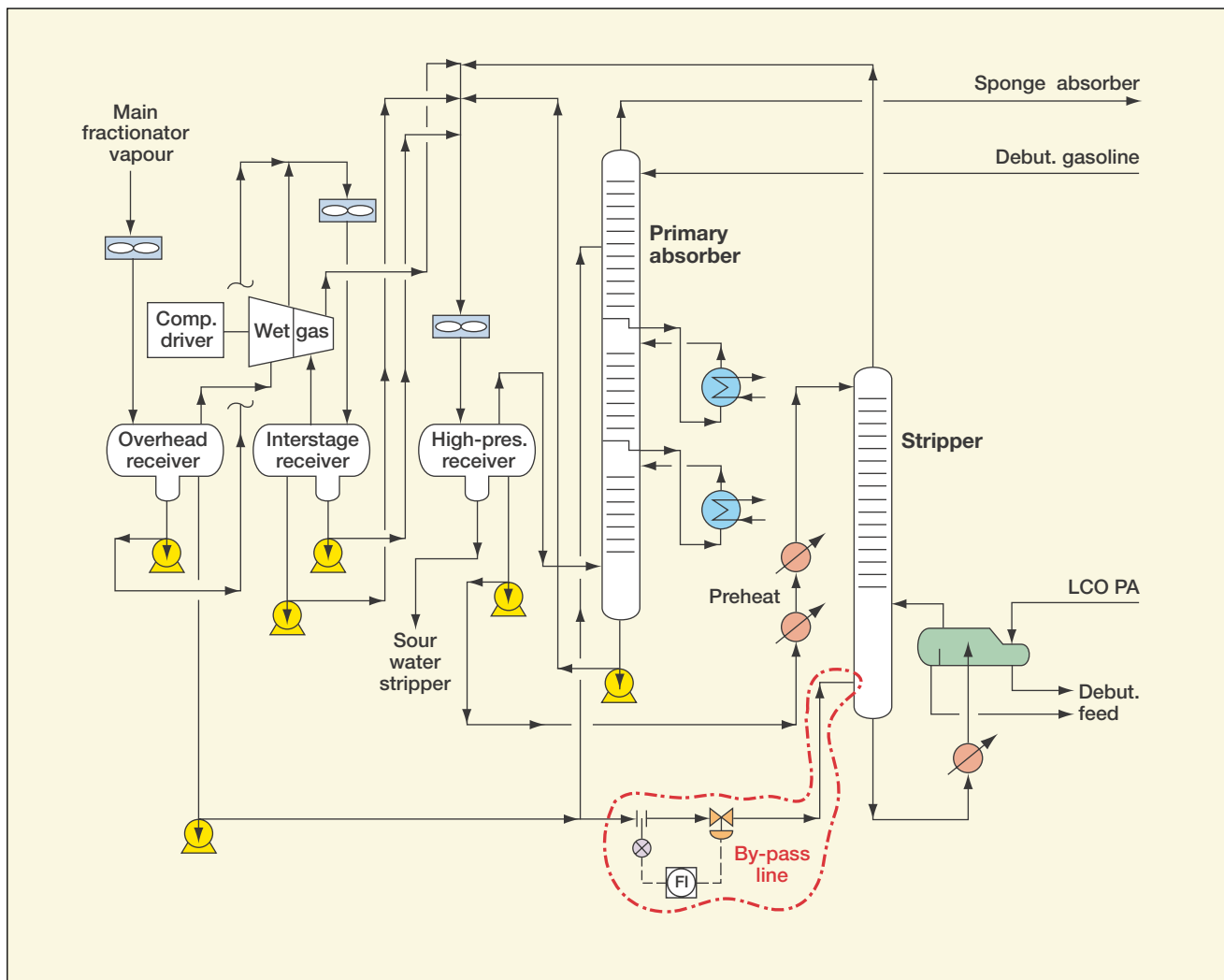

Figure 2 Stripper column bypass

stripper's feed rate (Figure 2). Even with these changes, the stripper column limited the FCCU's charge rate and conversion.

While the process flow scheme in Figure 1 is a generic depiction (eg, only one C_3 splitter is depicted), the Lindsey facility actually has two PP splitter units (noted as C_3 splitter in Figure 1), each with a different arrangement. They both serve the same purpose, but one utilises three towers: one tower operates as a separate deethaniser, followed by a two-shell PP splitter, essentially one for stripping and one for rectification. The other PP splitter unit achieves the same results in just one tower, with a C_2 stripping section provided at the top of the tower and the C_3 drawn as a side product.

Absorber/stripper systems

Primary absorber/stripper systems are the heart of the FCC GCU. These columns and the high-pressure (HP) receiver control C_3 recovery and C_2 rejection. Ideally, the stripper bottoms product's C_2 content is controlled at the maximum required to meet the GCU mixed C_3 s total allowable C_2 s of the previously noted 5000 ppmwt, because

this maximises C_3 recovery. Both columns are prone to flooding, with the stripper being the most problematic industry-wide. Primary absorbers operate at extremely high internal liquid rates, have moderate foaming tendencies, almost always flood due to inadequate downcomer top area or downcomer backup, and often flood at the intercooler draw or returns because of inadvertent restrictions. The stripper column also operates at extremely high liquid rates, with flooding initiated by either downcomer choke or backup flood mechanisms.

Rarely is jet flooding a problem in either the primary absorber or the stripper column. Moreover, the stripper can entrap water because the top temperature is too cold for all the water to go overhead, and the bottom temperature is too hot to allow the water to leave the bottom. This forces a water phase in the top and middle sections of the column, leading to severe flooding. When the stripper floods, it is not uncommon to rapidly fill the HP receiver, because the column feed rate is higher than the tray capacity. When the stripper floods, the FCC's charge rate must be lowered and the

reboiler's heat input drastically reduced. Unfortunately, large reductions in the stripper heat input can cause major excursions of residual C_2 s in the mixed C_3 s product exiting the GCU. In this case, total C_2 s increased to 20 000 ppmwt or higher.

The stripper experienced severe flooding following the 2000 revamp. In an effort to mitigate this, LOR installed a bypass to route some of the wild naphtha around the primary absorber/stripper columns, thereby reducing the stripper's feed rate. The wild naphtha maximum bypass was about 40 m³/hr out of a total stripper feed of 280 m³/hr. Therefore, the stripper's feed rate unloaded by up to 15%. However, as a liquid proportion of the main liquid to the primary absorber, the reduction was 25% or more, which reduced the primary absorber's internal liquid/vapour (L/V) ratio, thus reducing C_3 recovery. Furthermore, the wild naphtha contained more than 2000 ppmwt C_2 s and high H_2S , forcing the stripper column to overstrip its feed to meet the mixed C_3 s product's C_2 s specifications. While this improved the overall performance of the FCC, the C_2 s excursions still occurred.

Primary absorber/stripper system revamp

LOR's 2005 revamp installed new internals in the primary absorber/stripper columns, as well as a riser on the stripper feed draw nozzle in the HP receiver to improve oil/water separation. Primary absorber modifications included new trays with a larger downcomer top area and modifications to the intercooler draws to eliminate restrictions. These changes have allowed the FCC's feed rate and conversion to be increased without having to operate the wild naphtha bypass. Since startup, the unit has been tested at a maximum charge rate and conversion without any indications of either columns flooding. However, further charge rate increases have pushed the absorber/stripper system to a cooling limit. Thus, during summer operation, the GCU's offgas C_3+ content has increased from 8.0 to 12 mol%. Since this offgas is fed to a cryogenic gas plant where most of the C_3+ is recovered, the impact of reduced GCU $C_3=$ recovery on the overall $C_3=$ product yield is less discernible. This said, the GCU's operating objective is still to try to minimise C_3+ from the sponge absorber, because $C_3=$ recovery efficiency on the cryogenic unit is only 70% maximum. So directionally more $C_3=$ leaving the sponge absorber will result in more $C_3=$ loss to fuel, with significant economic penalty. Given the overall FCC economics, the $C_3=$ losses do not impact the feed rate/ROT policy despite the GCU's efforts to drive the losses from 12% back down to 8.0%.

All the stripper column's internals were replaced. The existing top downcomer area was too small and the active decks' open area was too low, resulting in downcomer backup flooding and downcomer choke flood. The tray open area was smaller in the top half of the tower than in the bottom, in an attempt to match the vapour load profile and the tray open area. The flooding profile was one of progressively increasing liquid/foam heights from the middle of the column upwards, until there was no discernible vapour space above the top four trays. Once the downcomer capacity was reached, the column pressure drop increased dramatically because the accumulation of liquid above the tray deck eventually filled the top of the column with liquid. This caused a massive liquid carryover into the HP receiver, resulting in a high liquid level.

Stripper column flooding is common due to extremely high liquid rates, difficulties separating the vapour carried into the downcomer and the presence of a water phase. Liquid flowing into the downcomers entrains vapour with it, the amount depending on a number of variables including tray design and liquid/vapour physical properties. The

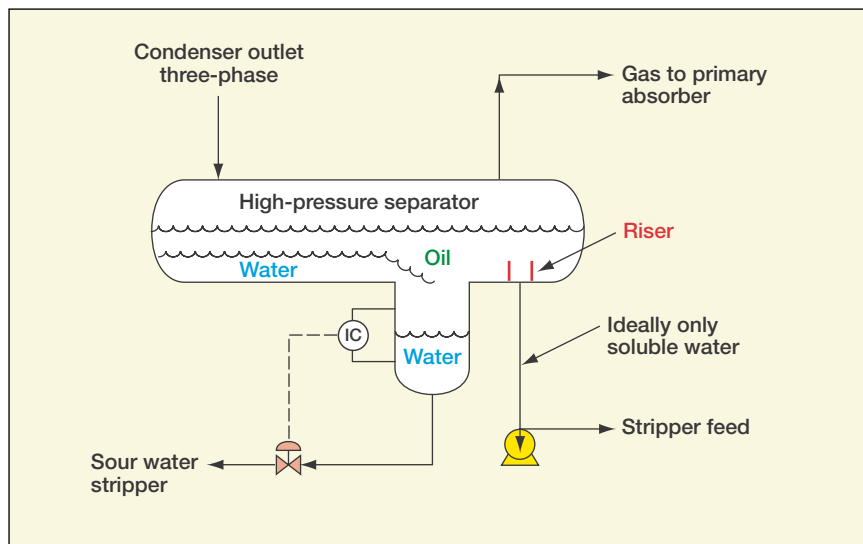

Figure 3 HP receiver oil and water separation

top downcomer area must be large enough to allow the entrained vapour to flow out at the same time as the liquid and vapour flow in. In an atmospheric crude column, it is possible to have liquid loadings based on the top area of the downcomer higher than 200 gpm/ft², whereas stripper downcomer loadings should not exceed 130 gpm/ft². Higher loadings choke the inlet, preventing additional flow into the downcomer and causing liquid to accumulate on the tray deck.

Downcomers also flood via a backup mechanism. Once the froth height in the downcomer reaches tray spacing, the column will flood. Since vapour is entrained with the liquid entering the downcomer, there is a density difference from the bottom of the downcomer to the top. Clear (or nearly clear) liquid is present in the bottom and an aerated froth in the top. In an atmospheric crude column, it may be possible to fill the downcomers by 50–60%, assuming a clear liquid level, whereas in the GCU stripper column the downcomer backup, assuming clear liquid, should not exceed 35% of tray spacing. The froth sitting on top of the clear liquid must be maintained below the tray level to prevent downcomer backup flood.

The absorber/stripper column trays must be designed with sufficient downcomer top area to prevent choke flood, and the downcomer backup must be kept at 35% or less of tray spacing based on clear liquid. Downcomer backup is a function of the weir height, downcomer clearance, weir liquid crest and tray open area. The designer needs to adjust these to maintain backup at or below 35%; otherwise, the trays will flood.

Stripper water phase

The water phase inside the stripper will flood the column prematurely. The two causes are free water in the feed from the

HP receiver, or low-temperature feed forcing a water phase to form even though there is only soluble water in the feed. Poor oil/water separation in the HP receiver results in free water in the feed. The HP receiver may be too small or there may be problems controlling the boot interface. Prior to the 2005 turnaround, LOR's HP receiver's hydrocarbon was withdrawn from the bottom of the receiver because the draw nozzle did not have a riser. Hence, when the water level reached the hydrocarbon draw, the stripper feed contained free water. During the 2005 turnaround, a riser was added to the HP receiver's hydrocarbon draw nozzle to prevent water from inadvertently being withdrawn (Figure 3).

A water phase forms inside the column when the feed is too cold. When the stripper feed is cold, the column needs a water draw in the top section to remove the water phase. LOR's stripper feed is heated prior to entering the column. Therefore, it will not form a water phase. However, to ensure any water in the feed could be withdrawn, a properly designed water draw was installed.

Revamp results

Since modifying the primary absorber/stripper column's internals, and making other changes in 2005, the FCCU has achieved record throughput and conversion. The stripper is no longer a constraint on capacity or fractionation efficiency. The wild naphtha bypass has been operated closed for several months without any flooding in the primary absorber/stripper columns. Currently, it is open to relieve a hydraulic constraint from the HP receiver's stripper feed pumps to the stripper column. As a consequence of this hydraulic limit, it has been impossible to flood the stripper column.

Prior to the 2005 revamp, the stripper

column's feed rate was maintained at 250 m³/hr with a maximum of 300 m³/hr by adjusting the wild naphtha bypass. Currently, the feed rate is approximately 400 m³/hr. Prior to the turnaround, the residual C₂s in mixed C₃s were in the region of 5000 ppmwt, with regular intolerable excursions up to 20 000 ppmwt or more. Since the revamp, the C₂s have been reduced to an average of 3000 ppmwt with less variation. Since the mixed C₃s product is further stripped in a deethaniser in front of one of the PP splitters, and in the deethanising section within the single PP splitter tower (and 5000 ppmwt C₂s is acceptable), there is probably some overstripping increasing the hydraulic load on the stripper feed system. But because of the inherent difficulties in controlling GCU stripper column bottoms product C₂ content precisely, and because of problems with the overhead gas meter from the column, further optimisation will have to wait until the gas meter can be put in service.

Following startup, there was some evidence of water accumulation on the stripper column's water draw tray, but more recently the level control valve has been in the closed position. LOR is constructing a sight glass to be able to crosscheck the oil/water interface controller on the tray. Since a riser was installed on the HP receiver's stripper

“Prior to the turnaround, the residual C₂s in mixed C₃s were 5000 ppmwt, with regular excursions up to 20000 ppmwt or more. Since the revamp, the C₂s have been reduced to an average of 3000 ppmwt with less variation”

feed draw nozzle, this potentially prevents entrainment of free water into the stripper. Although an improved water draw tray was specified for the stripper, there has been no clear evidence of water collection and decantation in the column.

The primary absorber has operated without capacity constraints, with the stripper debottlenecking permitting a higher flow of debutanised gasoline to the primary absorber. The C₃+ content of the sponge absorber off-gas is typically maintained at about 8.0 mol%, which is acceptable considering the cryogenic unit recovers most of this material. During the summer months, the

intercoolers and HP receiver's condensers operate at maximum heat removal, with the primary absorber's vapour line temperature increasing from its normal target of about 104°F (40°C) to higher than 113°F (45°C), which increases the C₃+ content to about 12 mol%. The tray hydraulic capacity has been tested by closing the wild naphtha bypass and increasing the recycle gasoline to maximum without any indication of flooding. Ultimately, the intercoolers and HP receiver's heat-removal limits, as well as the HP receiver-to-stripper hydraulic bottleneck, restrict the primary absorber and stripper column's feed rate rather than the previous column flooding.

Dave Langdon is a chemical engineer with Total Lindsey oil refinery, N Killingholme, Immingham, UK. Langdon graduated from Loughborough University of Technology, UK, with a BEng degree in chemical engineering.

Scott Golden is a chemical engineer with Process Consulting Services in Houston, Texas, USA. Email: sgolden@revamps.com

Edward Hartman is a process engineer with Process Consulting Services in Houston, Texas, USA. Email: ehartman@revamps.com
